

# **CAN Bridge**

User manual

Revision 6.1      03/2017

**Table of contents**

<b>Designation</b>	<b>3</b>
<b>Connection</b>	<b>3</b>
<b>Appendix A</b> [ZGW Pinout]	<b>4</b>
<b>Appendix B</b> [HU ISO connector pinout]	<b>5</b>
<b>Appendix C</b> [HU CIC Exx connection]	<b>6</b>
<b>Appendix D</b> [HU CIC Fxx MOST connection]	<b>7</b>
<b>Appendix E</b> [HU NBT connection]	<b>8</b>
<b>Appendix F</b> [HU NBT to ZGW connection]	<b>8</b>

## Designation

CAN bridge device is used for establish connection between any CAN ECU and diagnostic equipment.

This bridge is useful when need to make any diagnosis, coding, programming procedures to ECU without using vehicle gateway.

## Connection

To start connection, first, connect bridge to CAN buses. CAN1 wires (Yellow – CANH, Blue - CANL) connect to diagnostic equipment OBD cable pins. Pin6 of OBD connector is CANH, pin14 of OBD connector is CANL. CAN2 wires (Yellow/Black – CANH, Blue/Black - CANL) connect to appropriate CAN inputs of desired ECU.

If it necessary to send ignition ON state packets to CAN, close jumper on the box back side. Diagnostic equipment CAN bus speed is always 500Kbit/sec. CAN speed of ECU may variable from 83.3kbit/s to 500kbit/s. CAN speeds for both sides will detect automatically.

BUS activity can be checked by flashing CAN1 and CAN2 LEDs.



Fig 1

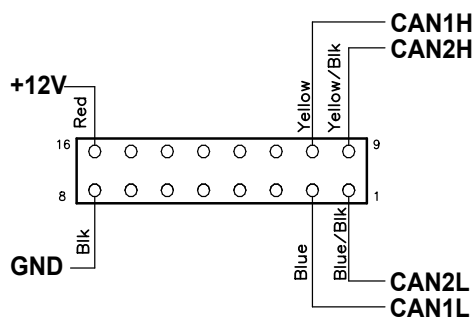

Fig 2

## Appendix A



Fig 3 ZGW pinout

Table 1 ZGW Pinout

Pin#	Name	Colour
50	K-CAN H	Orange/Green
51	K-CAN L	Green
48	K-CAN2 H	Yellow/Red
49	K-CAN2 L	Yellow/Brown
44	D-CAN H	White/Grey
45	D-CAN L	White/Green
42	+12V	
39	+12V	
19	GND	Brown/Black

## Appendix B

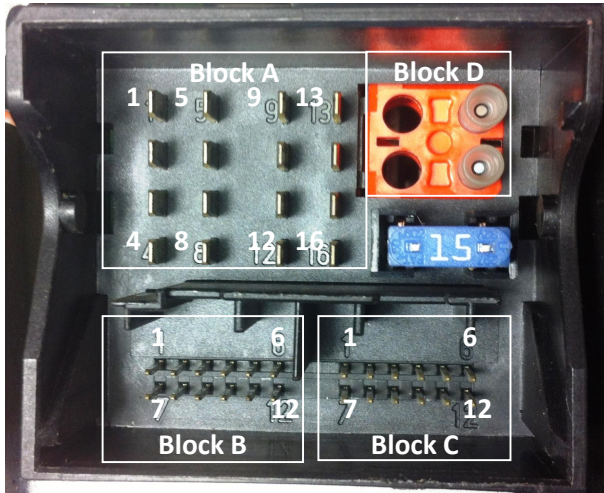

Fig 4 HU ISO Connector Pinout

Block B Pin Assignment	
Pin	Signal/Signalinfo
1	Microphone 1 In+
2	Microphone 2 In+
3	Microphone Shield
4	Microphone Out+
5	HU CAN Low
6	HU CAN High
7	Cradle Compensator On
8	Reserved
9	Microphone Ground
10	Microphone Out-
11	Reserved
12	Reserved

Block C Pin Assignment	
Pin	Signal/Signalinfo
1	Microphone 1 In+
2	Microphone 2 In+
3	Microphone Shield
4	Microphone Out+
5	HU CAN Low
6	HU CAN High
7	Cradle Compensator On
8	Reserved
9	Microphone Ground
10	Microphone Out-
11	Reserved
12	Reserved

Block A Pin Assignment	
Pin	Signal/Signalinfo
1	RR+
2	FR+
3	FL+
4	RL+
5	RR-
6	FR-
7	FL-
8	RL-
9	CANB Low
10	Telephone Mute
11	CANB High
12	U-Bat- (Clamp 31)
13	Reserved
14	CANB Shield
15	U-Bat+ (Clamp 30)
16	Electrical MOST Wake-up



Appendix D

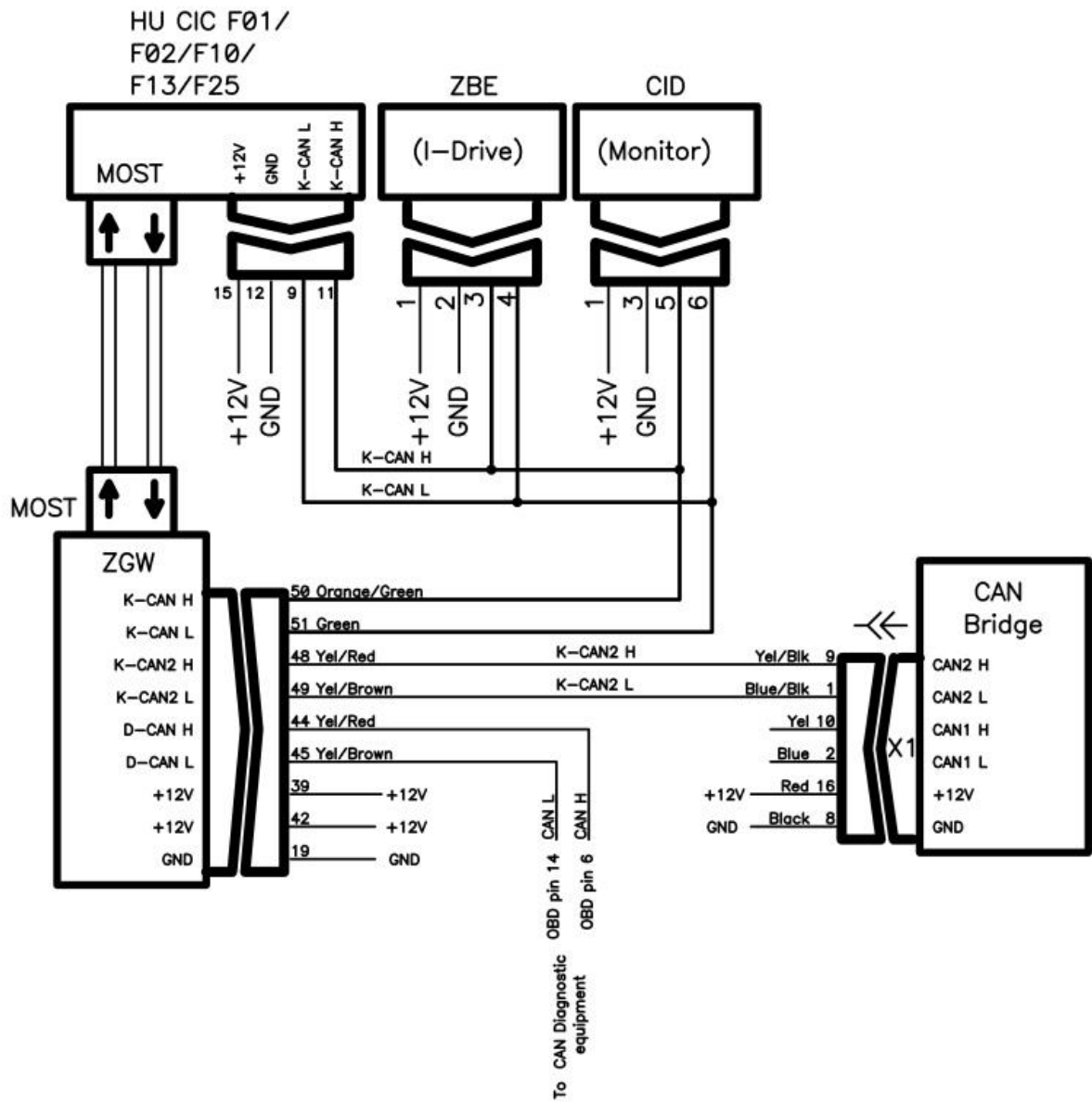

Fig 6 HU CIC Fxx MOST connection

Appendix E

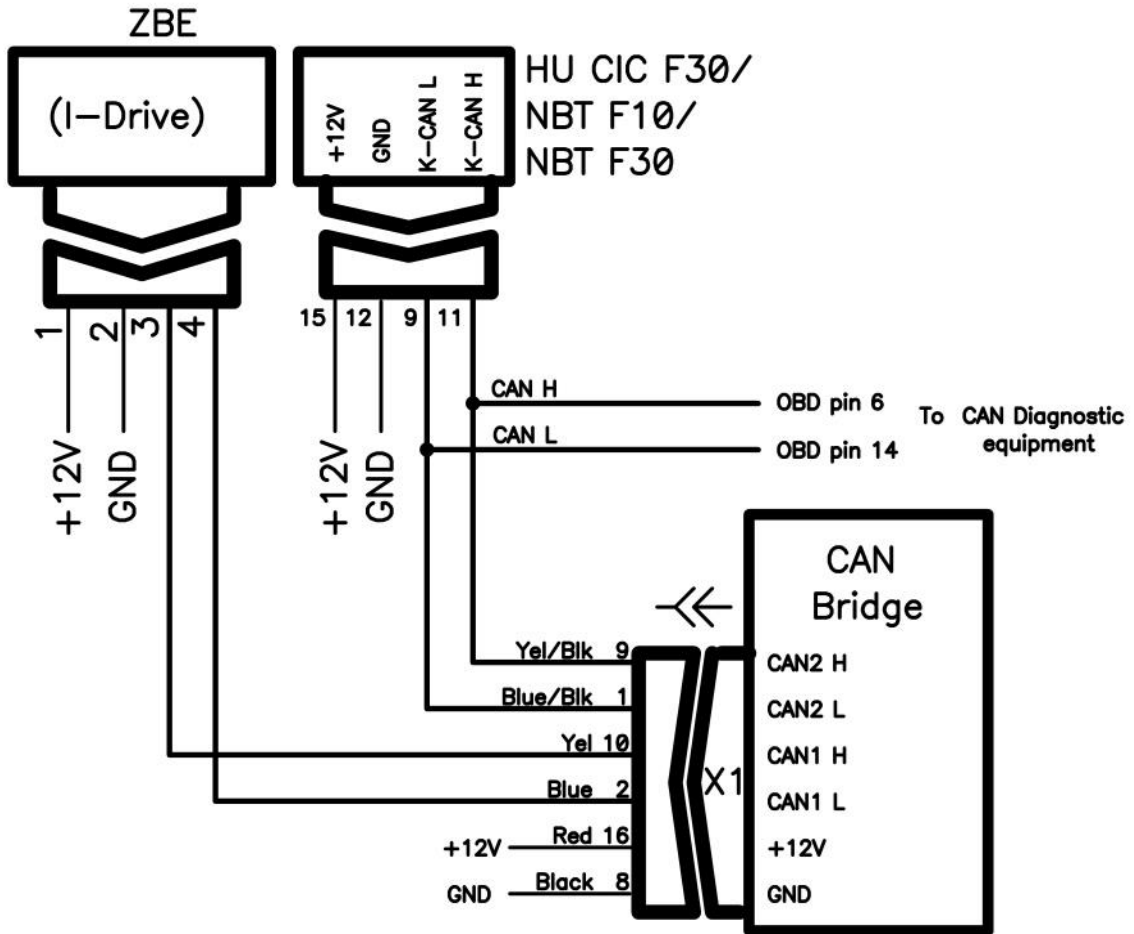

Fig 7 HU NBT connection



Appendix F

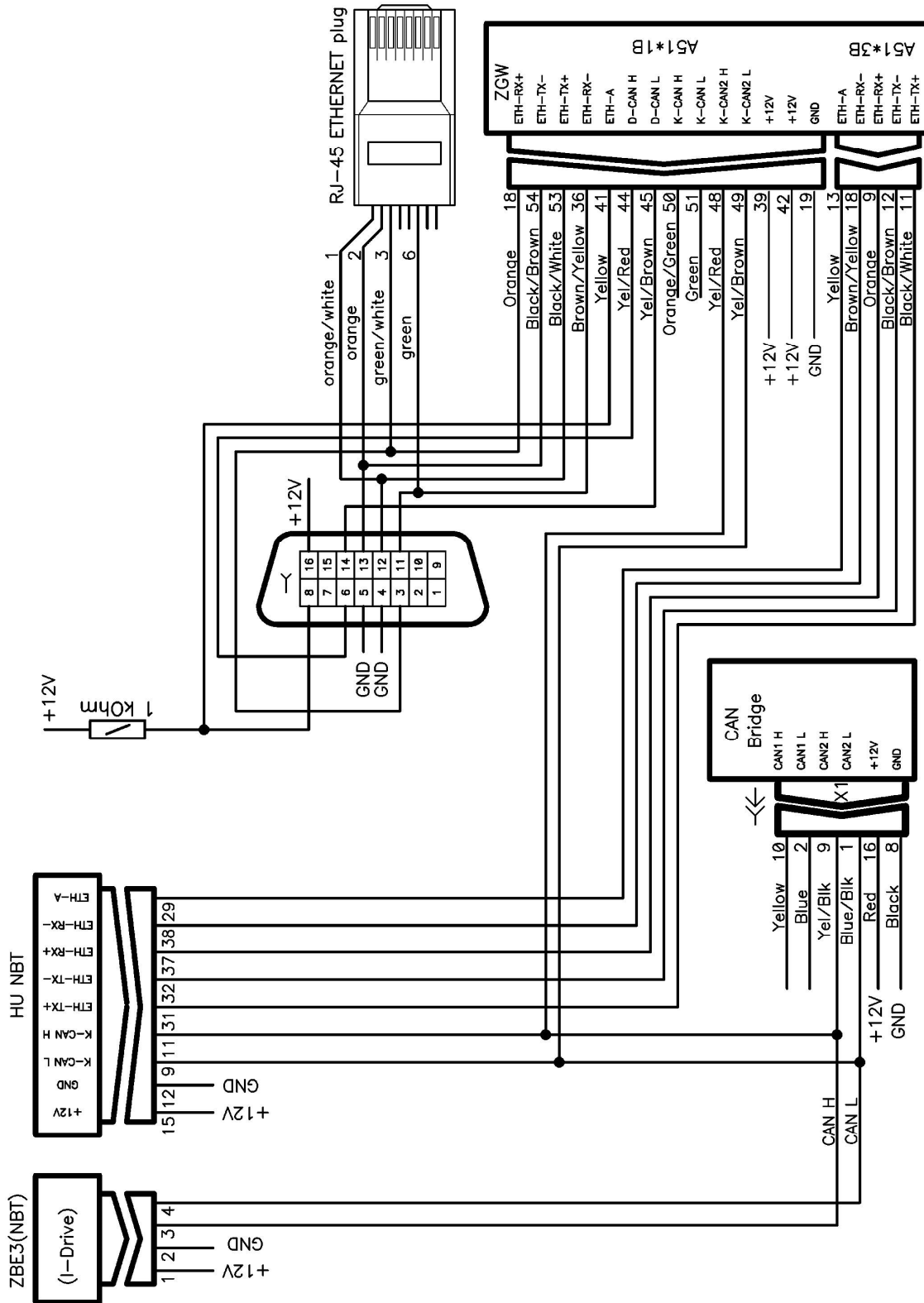

Fig 8 HU NBT to ZGW connection