

NTG4.5/NTG5 Navi activator User and Installation Manual

Software Version 1.02.00.

User and installation manual

Revision 10 12/2015



READ THIS INSTALLTION MANUAL CAREFULLY BEFORE YOU START!

It is strongly recommended to perform this installation by using services of installer with appropriate knowledge and experience in automotive electronics. Installation should be performed with disconnected battery due to safety reasons.

Table of contents

Designation	3
Technical description	4
Connection	5



Attention! Using the navi activator can lead to activation of the "Anti Theft" mode in the head unit. Before using navi activator make sure you have the correct PIN code for deactivation of the "Anti Theft" mode with diagnostic equipment.

Designation

The module is designed to activate the navigation in Mercedes Benz head units NTG4.5, NTG5 when replacing or installing the head unit in another car. This option can be switched with SW0 switch for NTG5, or SW1 switch for NTG4.5.

Module has speed filter function (allows viewing TV programs or video from AV-in sources while driving). This function can be switched with SW2 switch.

The module is also has function of initial startup of the COMAND, which activated by a short-term closure of the green/black wire to + 12V. This feature performs "binding" (Anti Theft deactivation) COMAND to the vehicle without the need for diagnostic equipment. This function is possible only with a pre-prepared COMANDs.

Technical description

Adapter contains 8 switches for configuring its options. Designation of the switches is in Table 1.

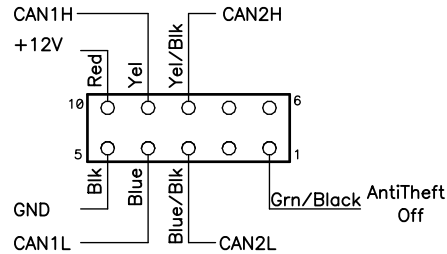

Fig 1 Pinout

Table 1

	SW0	SW1	SW2	SW3	SW4	SW5	SW6	SW7
Switch shortened (Closed)	Replace incoming activation data with activation data from headunit	Replace incoming activation data with activation data from internal flash memory	“Video in Motion” mode On	S/N change On			See table 2	
Switch not shortened (opened)	Activation data not changed	Activation data not changed	“Video in Motion” mode Off	S/N change Off				

Table 2

	SW6	SW7
NTG4.5, NTG4.7	Off	Off
NTG5s1	Off	On
NTG5.0	On	On

Table 3 Recommended switches configuration

	SW0	SW1	SW2	SW3	SW4	SW5	SW6	SW7
NTG4.5, NTG4.7	Off	On	On	Off	Off	Off	Off	Off
NTG5s1	On	Off	On	Off	Off	Off	Off	On
NTG5.0	On	Off	On	Off	Off	Off	On	On

Connection

For adapter installation necessary CAN bus should be cutted. CAN pair from side of COMAND must be connected to CAN2 pair of the adapter (CANH – yellow/black, CANL – blue/black). Second pair (from car side) – to CAN1 pair of the module (CANH - yellow, CANL - blue).

Adapter powered from **constant** +12V supply. +12V – red wire, GND – black wire.

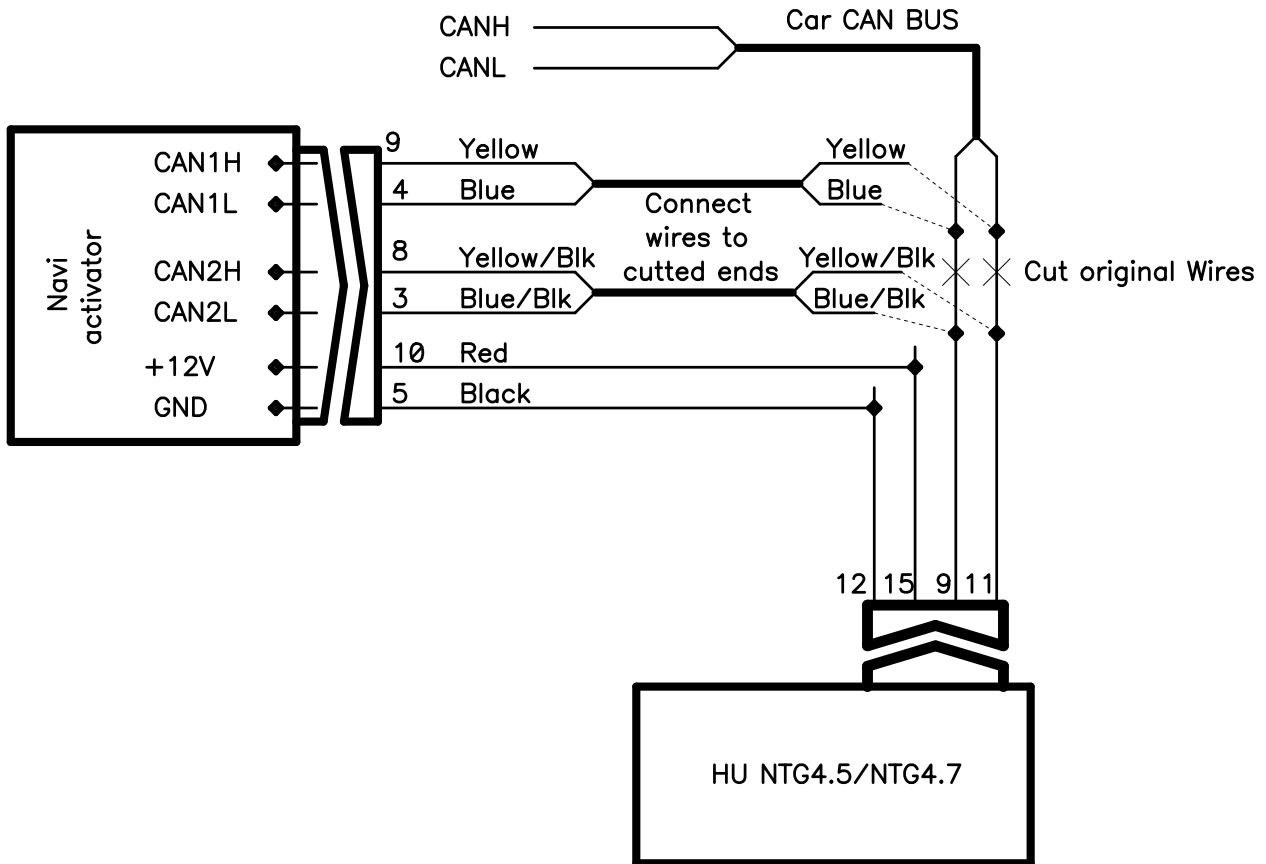

9 - CANL
11 - CANH

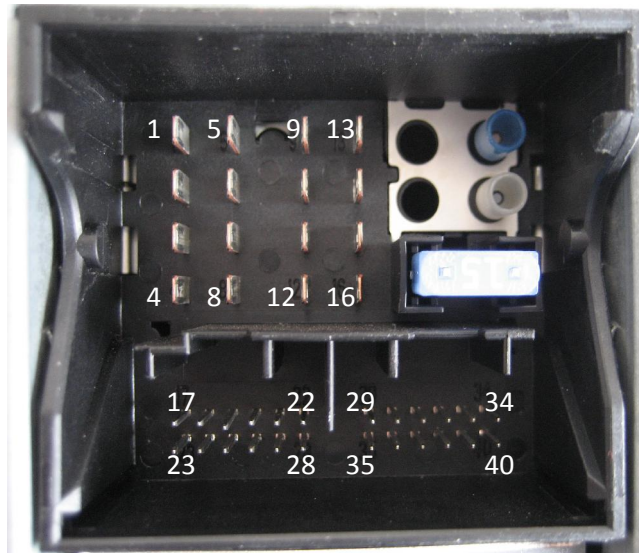

NTG4.5/NTG4.7 HU Socket pinning

Notes

Notes

Notes